

RETRACTED POSITION:

A	B	C	D	E*	E1**	F*	F1**
18°	22'-8"	27'-7"	32'	6'-6"	6'-8"	7'-10"	9'-10"
20°	24'	27'-1"	31'-6"	6'-5"	6'-8"	7'-7"	9'-7"
25°	27'-4"	25'-7"	30'	6'-4"	6'-8"	6'-11"	9'
30°	30'-7"	23'-10"	28'-2"	6'-1"	6'-8"	6'-4"	8'-4"
35°	33'-7"	21'-9"	26'-2"	5'-10"	6'-7"	5'-10"	7'-9"
40°	36'-5"	19'-5"	23'-10"	5'-6"	6'-5"	5'-3"	7'-1"
45°	39'-1"	16'-10"	21'-3"	5'-1"	6'-2"	4'-9"	6'-6"

* Lower Chute in line with main chute.
(Lower chute extension not included)

** Lower chute extended to maximum upward position.
(Lower chute extension not included)

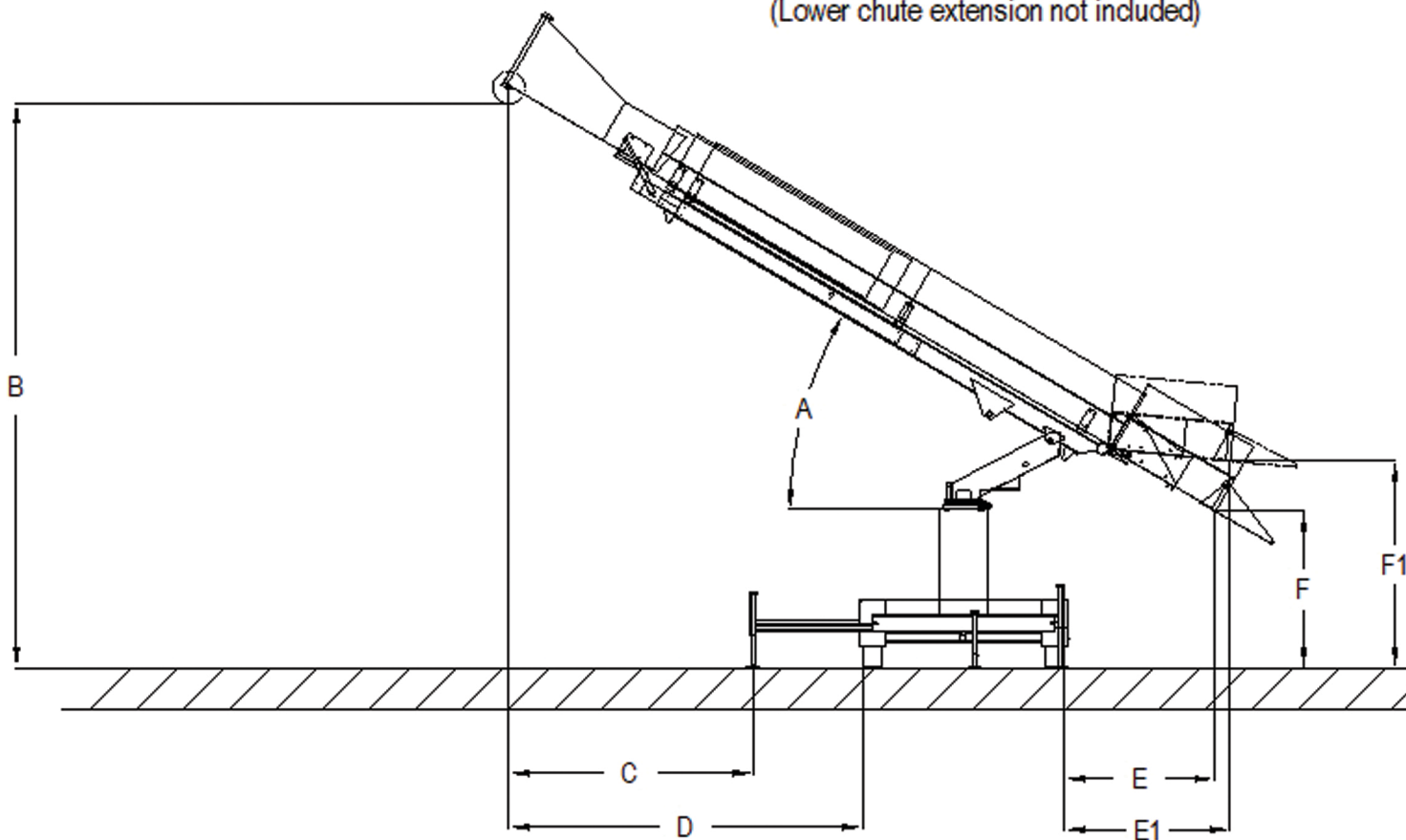

EXTENDED POSITION:

A	B	C	D	E*	E1**	F*	F1**
18°	17'-8"	12'-5"	16'-9"	6'-6"	6'-8"	7'-10"	9'-10"
20°	18'-7"	12'-1"	16'-5"	6'-5"	6'-8"	7'-7"	9'-7"
25°	20'-7"	11'-1"	15'-6"	6'-4"	6'-8"	6'-11"	9'
30°	22'-7"	9'-11"	14'-4"	6'-1"	6'-8"	6'-4"	8'-4"
35°	24'-5"	8'-8"	13'-0"	5'-10"	6'-7"	5'-10"	7'-9"
40°	26'-2"	7'-2"	11'-7"	5'-6"	6'-5"	5'-3"	7'-1"
45°	22'-7"	5'-7"	10'-0"	5'-1"	6'-2'	4'-9"	6'-6"

* Lower Chute in line with main chute.
(Lower chute extension not included)

** Lower chute extended to maximum upward position.
(Lower chute extension not included)

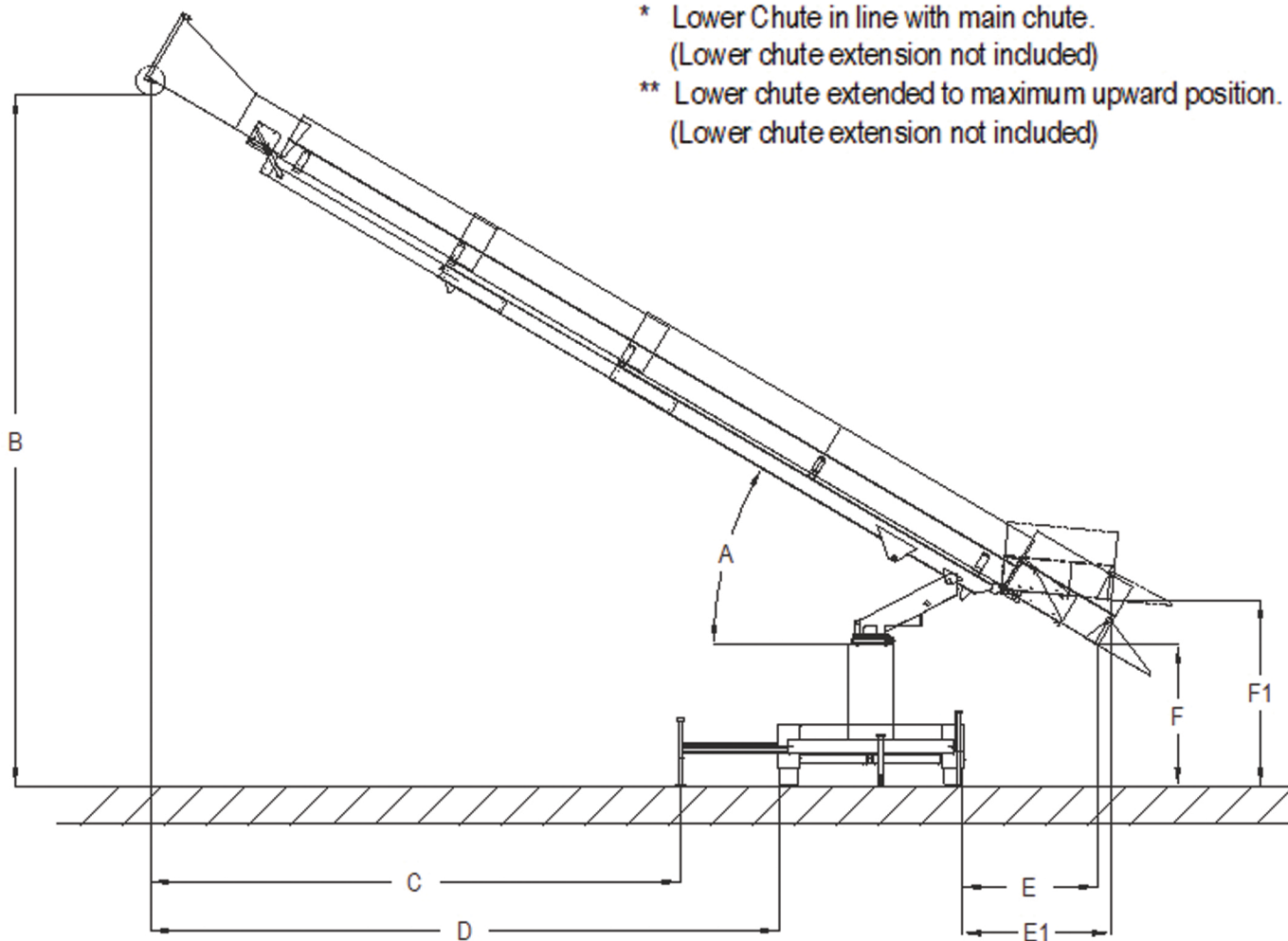

TOWING & STORAGE POSITION:

